

WENTYLATOR PRZECIWWYBUCHOWY WBE (DO 13800 M³/H)



Wentylator przeciwwybuchowy WBE służy do przetłaczania gazów, par lub pyłów wybuchowych.

Wentylatory produkowane w dwóch wersjach:

WBE – wentylatory do pracy w strefach Z1 (1) i Z2 (2) zagrożenia wybuchem gazów

Klasa temperaturowa: od T1 do T3 (na specjalne zamówienie T4)

Temperatura otoczenia: do +40stC

Grupa wybuchowości: II (mieszanki podgrupy IIA i IIB)

Wentylatory nieprzystosowane do regulacji obrotów.

WBE 3G/3D – wentylatory do pracy w strefach Z2 (2) i Z22 (22) zagrożenia wybuchem gazów i pyłów

Klasa temperaturowa dla gazów: od T1 do T3

Maksymalna temp. powierzchni dla pyłów do 120stC

Temperatura otoczenia: do +40stC

Grupa wybuchowości dla gazów: IIA i IIB

Grupa wybuchowości dla pyłów: IIIB

Wentylatory przystosowane do regulacji obrotów atestowanym przemiennikiem częstotliwości.

Dane techniczne

	Wydajność(max) [m ³ /h]	Spręż(max) [Pa]	Moc [kW]	Obroty [obr./min]	Zasilanie [V]
WBE-16 M	800	200	0,12	1400	400
WBE-16 M 3G/3D	800	200	0,12	1400	400
WBE-16 D	1450	675	0,75	2800	400
WBE-16 D 3G/3D	1450	675	0,75	2800	400
WBE-18 M	1440	205	0,25	1400	400
WBE-18 M 3G/3D	1440	205	0,25	1400	400
WBE-18 D	2180	1000	1,5	2800	400
WBE-18 D 3G/3D	2180	1000	1,5	2800	400
WBE-20	1930	380	0,37	1400	400
WBE-20 3G/3D	1930	380	0,37	1400	400
WBE-25 M	1680	180	0,37	900	400
WBE-25 D	3180	485	0,75	1400	400
WBE-25 D 3G/3D	2180	485	0,75	1400	400
WBE-31 M	3460	320	0,75	900	400
WBE-31 M 3G/3D	3460	320	0,75	900	400
WBE-31 D	5400	710	2,2	1400	400
WBE-31 D 3G/3D	5400	710	2,2	1400	400
WBE-35 M	7200	530	2,2	900	400
WBE-35 M 3G/3D	7200	530	2,2	900	400
WBE-35 D	13800	1220	7,5	1400	400
WBE-35 D 3G/3D	13800	1220	7,5	1400	400

Charakterystyki

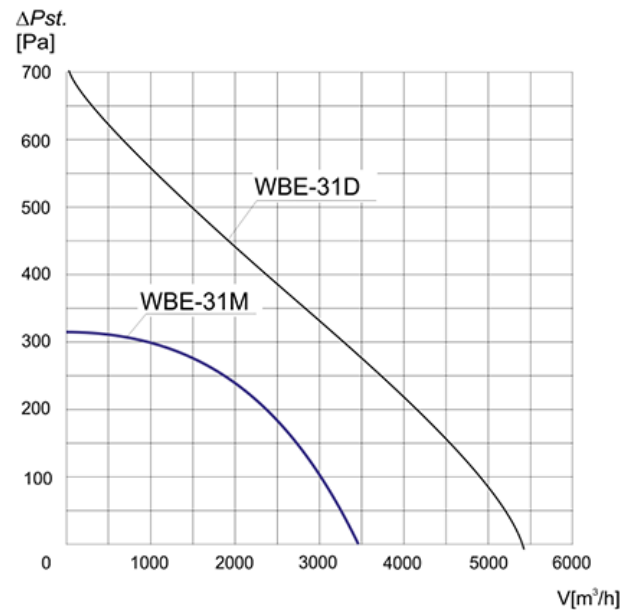
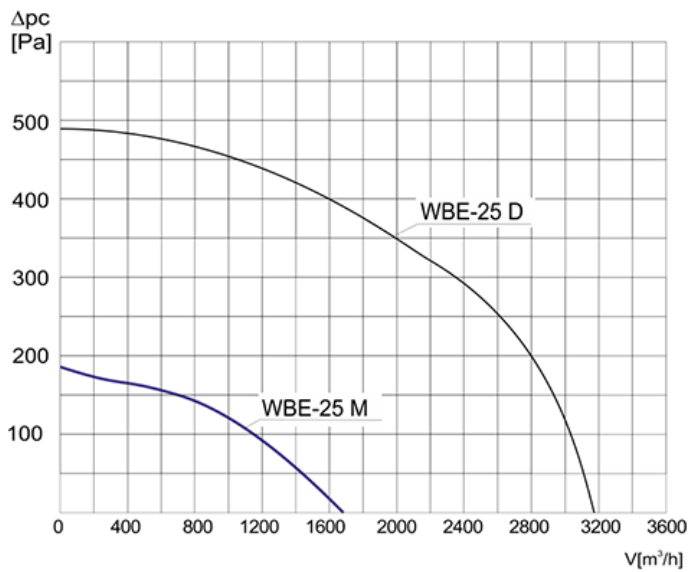
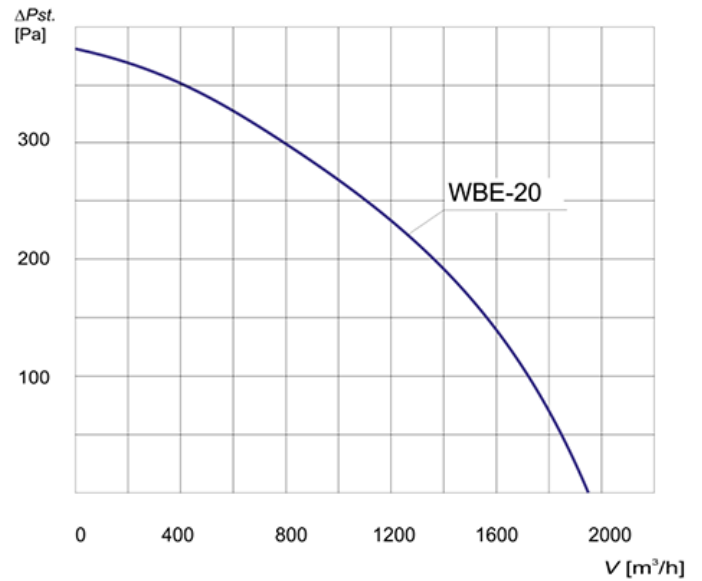
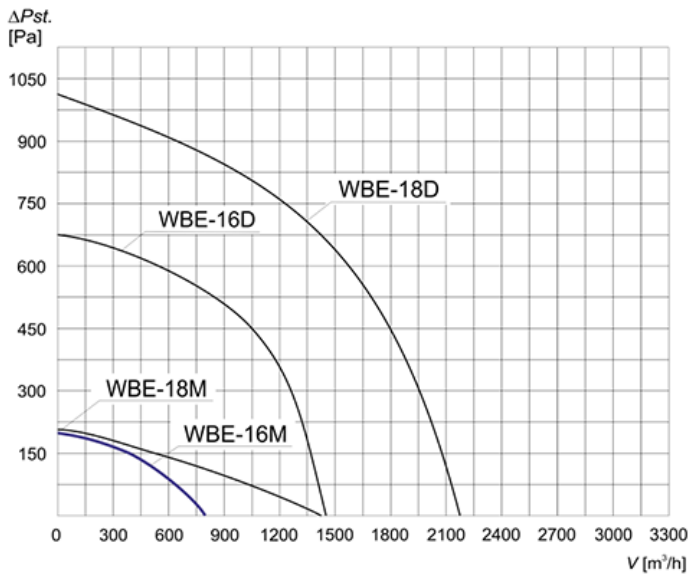

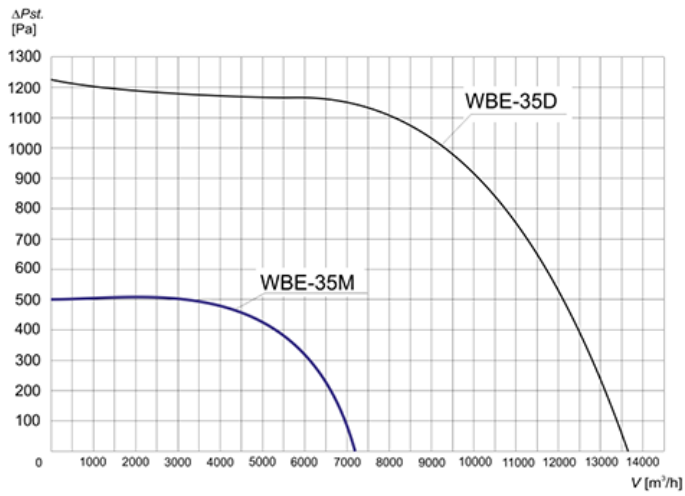

Wymiary

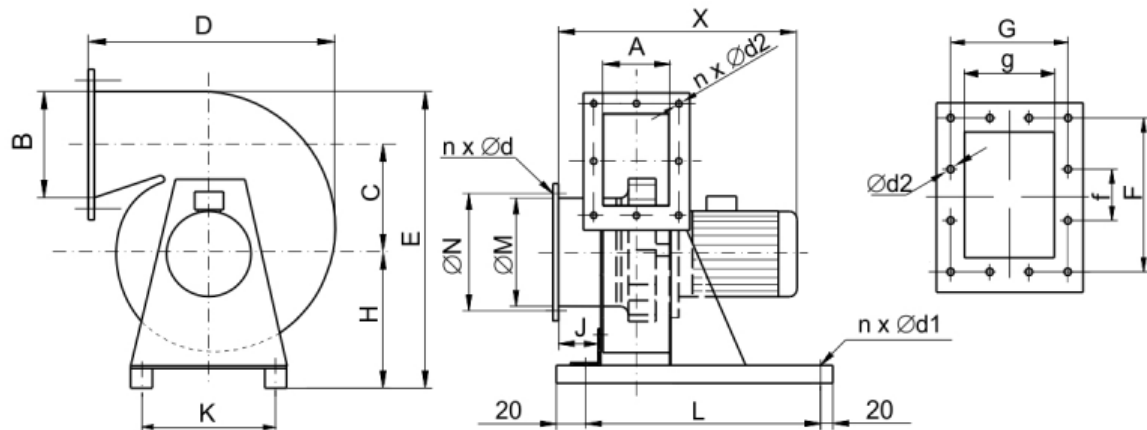

	A	B	C	D	E	H	K	M	N	n x Ød	J	L	X	n x Ød1	G	g	F	f	n x Ød2
	[mm]	[mm]	[mm]	[mm]	[mm]	[mm]	[mm]	[mm]	[mm]	[mm]	[mm]	[mm]	[mm]	[mm]	[mm]	[mm]	[mm]	[mm]	[mm]
WBE-16	125	112	95	249	307	156	180	160	185	4x7	40	350	430	4x7	149	-	136	-	4x7
WBE-18	125	160	125	327	395	190	230	160	185	4x7	60	400	520	4x7	149	-	184	-	4x7
WBE-20	160	160	160	382	455	215	230	200	225	4x9,5	50	400	460	4x7	1844	-	184	-	4x7
WBE-25	180	200	180	450	523	243	310	250	275	4x9,5	50	450	500	4x7	204	140	224	140	12x7
WBE-31	200	250	220	525	630	285	350	315	352	8x9,5	60	500	600	4x10	232	140	282	140	12x10
WBE-35	250	315	265	654	766	344	500	500	392	8x9,5	80	550	770	5x10	282	140	347	140	12x12